

Richter PFA/PTFE Shut-off and Control Butterfly Valves

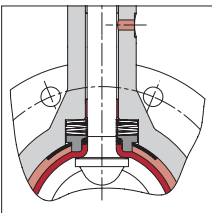
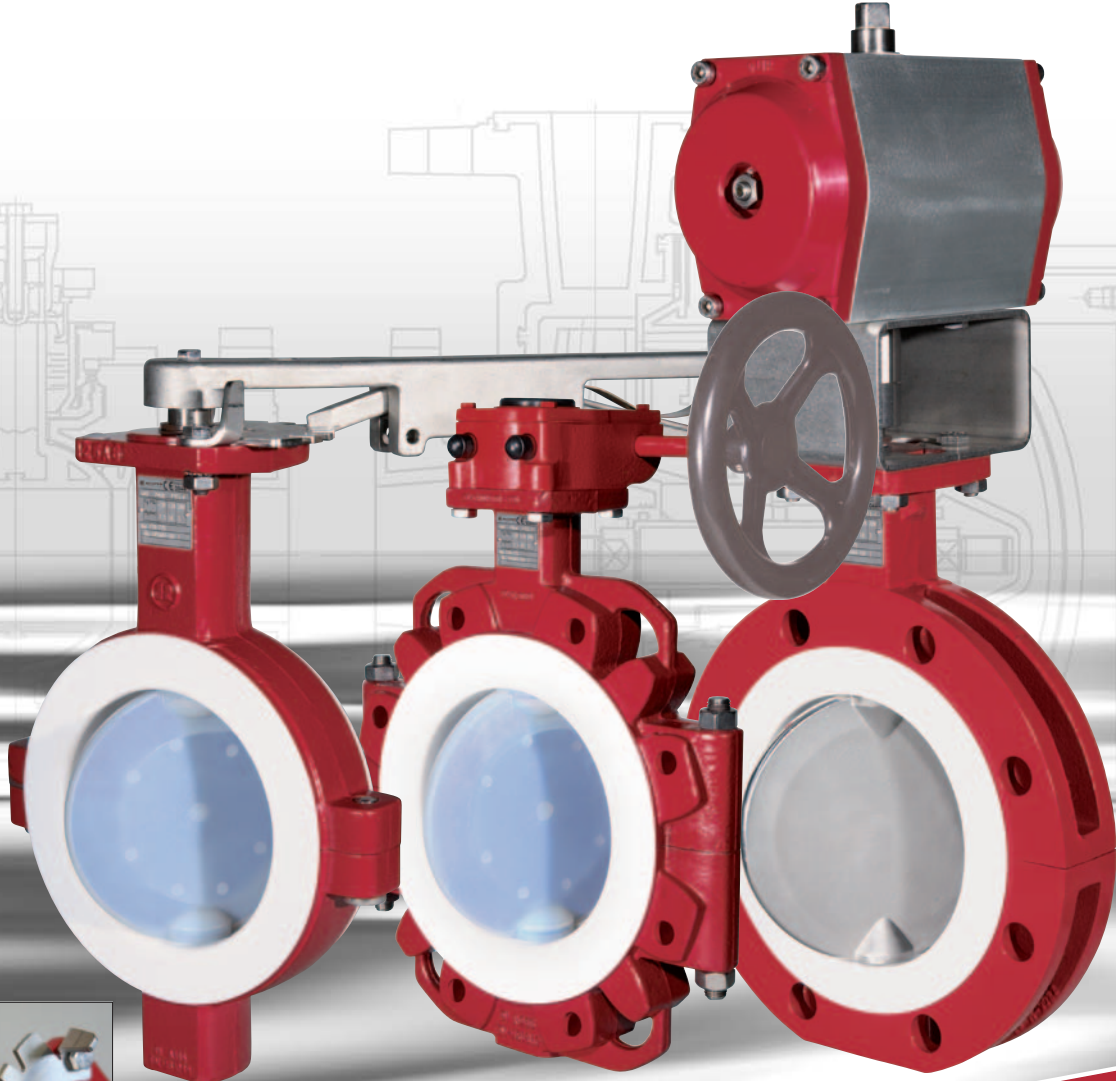

New:

- Sizes to 40" (1000 mm)
- Titanium, PE-UHMW

Body lining PTFE, TFM-PTFE,
PTFE-antistatic, PE-UHMW

Disc/stem unit PFA,
PFA-antistatic,
SS, Hastelloy®, Ti,
special metals

Clean Air Act Conformity



Richter wafer-style, lug-style and double-flange butterfly valves

Fields of application

Richter butterfly valves have proved successful in a wide variety of process plants.

- Shut-off, throttling and control of corrosive, hazardous and pure liquids, gases and vapours, e.g.
 - wet Cl₂ gas and NaOH in chlor-alkali electrolysis
 - large flows in the distribution and treatment of H₂SO₄, HCl, NaOH, NaOCl, chemical effluent etc.
- FDA-compliant, wetted materials for use in food processing, pharmacy and similar fields.
- Also suitable for free-flowing, low-abrasive bulk materials in the version with a metallic disc/stem unit.
- The compact butterfly valves are advantageous in confined spaces – e.g. under vessels.
- Butterfly valves are economical valves: easy to install and dismantle, attractively priced, compact.

Operating range

- -40 °F to +400 °F (-40 °C to +200 °C)
- 0.0015 psi to 145 psi vacuum (0.1 mbar to 10 bar vacuum)

Product features

- Soft-sealing and gas-tight, both with lined and metallic disc/stem unit
- Leak-tight against the atmosphere in compliance with the German Clean Air Act (TA-Luft)
- Optional with safety stuffing box (series NK, NKS, NKL)
- Leakage rate in the seat to DIN EN 12266, leakage rate A (formerly DIN 3230 T3): gas-tight, 0 bubbles
- Almost equal-percentage characteristics
- Face-to-face: ISO 5752 series 20, API 609 Table 1, MSS SP-67 Table 3
- Flanges (with lug-style and double-flange bodies) for connection to ISO 7005-2 PN10, ASME (ANSI) B16.5 Class 150, JIS R 2210-10K
- Anti-adhesive wetted surfaces thanks to PFA/PTFE
- Identification of the valves: DIN EN 19, ASME (ANSI) B16.34
- Actuation: - hand lever, lockable
 - worm gear with handwheel
 - pneumatic/electric actuators

Type code, wetted linings and available sizes

- see page 10

Depending on the body version, the butterfly valves can be installed

- **As a wafer-style valve** (“sandwich-type”) with all three body versions or
- **As a flange-mounted or dead-end butterfly valve** with lug-style and double-flange body.

① Single-piece disc/stem unit optionally fluoroplastic

- Lined with **pure PFA** for **maximum corrosion resistance** and **a long service life**.

Very low friction values and torques during opening and closing due to the combination of a PFA disc/stem unit with a PTFE body

- Optionally antistatic PFA-L
- Disc/stem core made of highly torsionresistant Duplex stainless steel 1.4517/CD-4 MCu (18“-40“/DN 450-1000: SS 1.4435/316L)

Alternatively metallic

- **Made of precision cast stainless steel**
 - Polished sealing surfaces, therefore very low friction values
 - Polished disc surfaces on request
- **Other materials on request, e.g. Hastelloy® C, titanium**

② Thick-walled PTFE and TFM-PTFE lining of the valve body

- TFM-PTFE lining (2“-16“/DN 50-400 with PFA-lined disc: PTFE as standard, optionally TFM-PTFE)
- Lining thickness 0.12- 0.15“ (3 -3.5 mm)
- High permeation resistance
- Vacuum-proof
- Optionally antistatic PTFE-L, PE-UHMW

Wide sealing surfaces of body lining

for reliable sealing even with mating flanges with large radii, e.g. glass-lined components

③ Permanently elastic seal in the valve opening by means of silicone insert

- under the PTFE body lining.
- Optionally FKM insert (e.g. Viton®) for use with chlorine gas for example

④ **Double-action, maintenancefree and self-adjusting top and bottom stem sealing,**

therefore reliable even with many switching cycles and fluctuating temperatures:

- primary: body lining against disc/stem shoulder
- secondary: O-ring FKM, optionally FFKM

Compliant with the German Clean Air Act

even in the standard version without safety stuffing box

⑤ **Pressure-bearing body made of ductile cast iron**

EN-JS 1049 ≈ ASTM A395

- Absorbs system and pipe forces
- Centers the valve in the pipe
- Optionally body made of stainless steel or carbon-fibre/glass-fibre-reinforced vinyl ester

⑥ **Long valve neck**

permits optimal heat insulation without the installation of an elevated lever, additional stem extensions on request.

⑦ **External corrosion protection**

Epoxy coating, nuts and bolts made of stainless steel

⑧ **Centering to ISO 5211**

Chlorine electrolysis options

Specially for use with wet chlorine gas:

- Elastic insert made of Viton® instead of silicone
- Body lining made of particularly permeation-proof, modified TFM-PTFE instead of standard PTFE
- Body nuts and bolts made of steel, for example, instead of stainless steel
- Tantalum-coated ductile iron body

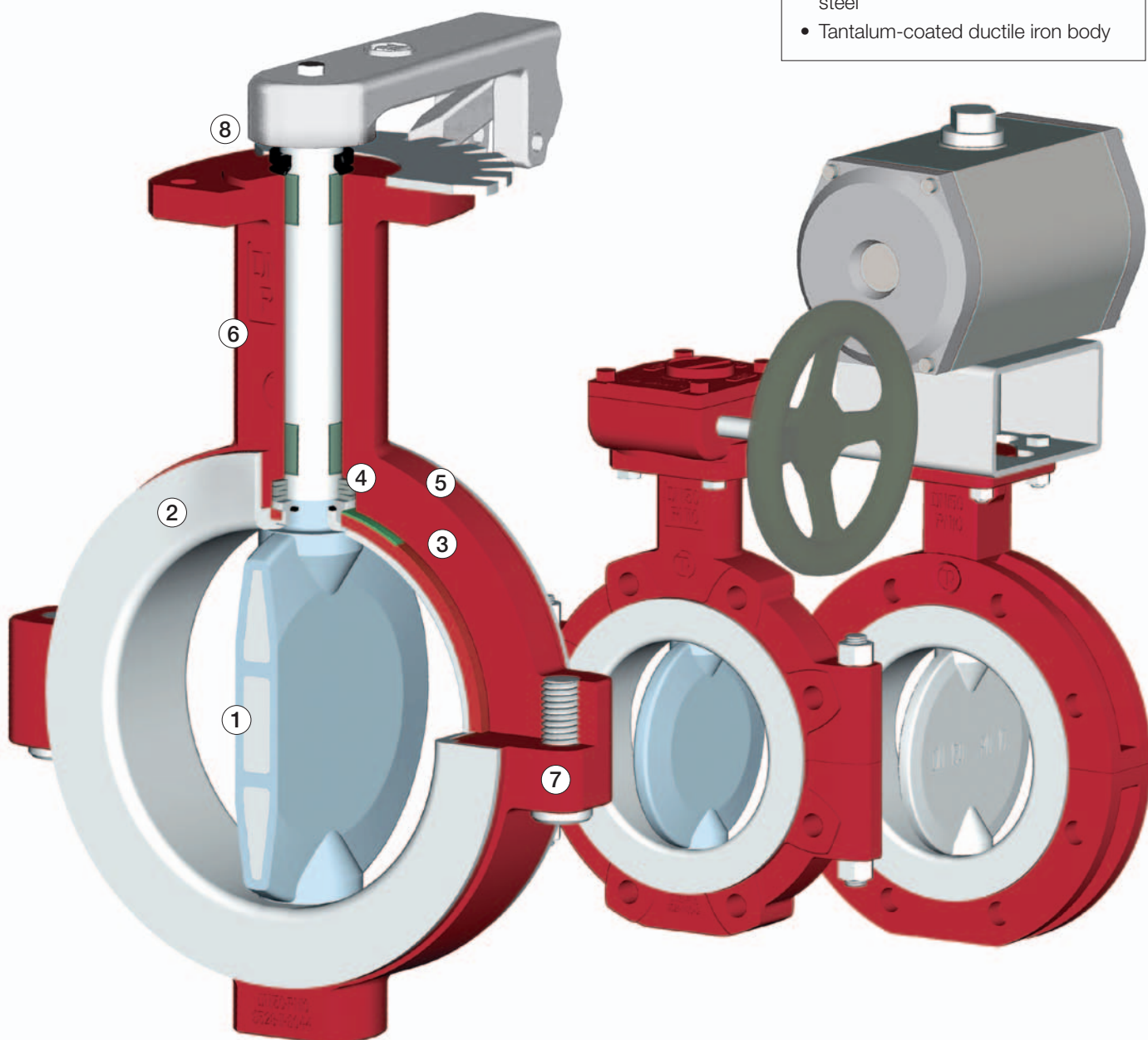

Wafer-style body
NKS, NKS-C

Lug-style body
NKL, NKL-C

Double-flange body
NK

Components, materials and options for valves with stainless steel/Hastelloy® C/titanium disc

Components and materials

Item	Designation	Standard design 2"-40" (DN 50-1000)	Special design
120	Body (shell)	Ductile cast iron EN-JS 1049 ≈ ASTM A395	Stainless steel, CF-/GF-reinforced vinyl ester
221	Disc/stem unit, one-piece	2"-8" (DN 50-200): Duplex stainless steel 1.4470/ ASTM A890 4A 10"-40" (DN 250-1000): Stainless steel 1.4404/316L	Hastelloy® C22, titanium gr. 2
235	Hand lever (2"-8", DN 50-200)	Stainless steel, from 8" (DN 200) worm gear with handwheel	
313	Complete bearing and pressure set	Details on request	
409	Body lining	TFM-PTFE	PTFE antistatic, UHMW-PE
510	Bracket	Stainless steel, Connection to ISO 5211 + Namur	Special design on request
519	Throttling plate	Stainless steel, scaling 10°	
521	Flexible insert	Silicone	FKM (Viton® or equivalent), FDA-FKM
804	Coupling	Stainless steel	Special design on request
850	Actuator	Pneumatic quarter-turn actuators e.g. Richter RA, Norbro, El-o-matic, AMG, AirTorque etc.	Pneumatic or electric actuators of various makes
857	Worm gear with handwheel (not illustrated, see page 4)	Body cast iron EN-GJL 25 (GG-25) with epoxy coating	Body ductile cast iron, aluminium stem with O-ring sealing, stem and bolts stainless steel
w/o No.	Stem extension, not illustrated		Design on request
w/o No.	Screws, nuts, washers	Stainless steel	on request

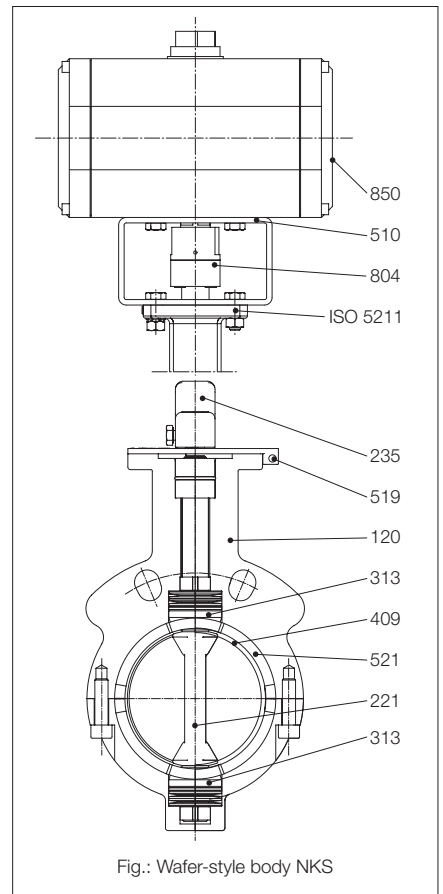

Option: Butterfly valve with CF/GF-reinforced vinyl ester body

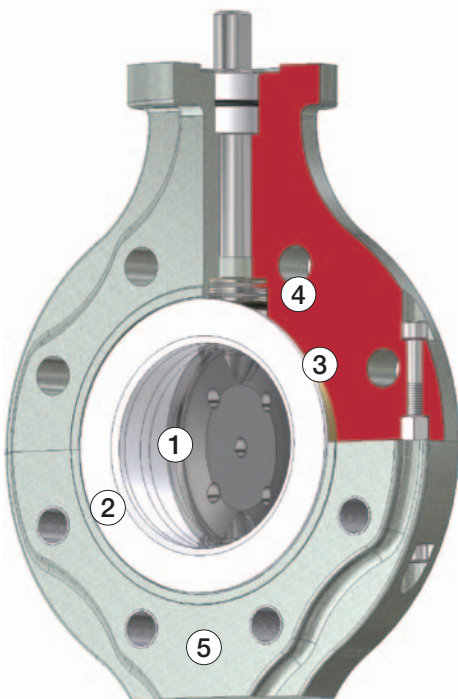



- ① **Disc/stem unit plastic-lined or metallic**
 - PFA-lined, PFA antistatic, stainless steel, Hastelloy® C22, titanium gr. 2
 - ② **Body lining TFM-PTFE**
 - Highly corrosion-resistant, vacuum-proof
 - Optionally TFM-PTFE antistatic, PE-UHMW highly abrasion-resistant
 - ③ **Permanently elastic seal in the valve passage by means of silicone insert**
 - Optionally FKM insert (e.g. Viton®)
 - ④ **Self-adjusting, maintenance-free stem sealing**
 - Leak-tight against atmosphere, German Clean Air Act (TA Luft)
 - Double-acting with secondary O-ring
 - ⑤ **Shell made of vinyl ester thermosetting plastic with 20 % carbon-fibre/glass-fibre reinforcement**
 - Wafer-style or lug-style body
 - High dimensional stability, low weight, antistatic
 - High resistance to atmospheric corrosion
 - 2"-12" (DN 50-300), operating pressure up to 145 psi (10 bar)
 - -20 to +265 °F (-30 to +130 °C) with TFM-PTFE,
 - -20 to +195 °F (-30 to +90 °C) with PE-UHMW
 - Face-to-face ISO 5752 series 20, API 609 Table 1, MSS-SP 67 Table 3
 - Seat leakage rate to DIN EN 12266, leakage rate A: gas-tight, 0 bubbles
- Connecting dimensions, pressure/temperature range, flow rates and torques: details on request

NK, NKS, NKL, NKS-C, NKL-C

Connection dimensions, flow rates, torques

PTFE and TFM-PTFE butterfly valves with **PFA-lined disc**

Series	NKS, NKSP		NKS-C, NKSP-C		NKL, NKLP		NKL-C, NKLP-C		NK, NKP	
Actuation	Lever	Gear/Actuator	Lever	Gear/Actuator	Lever	Gear/Actuator	Lever	Gear/Actuator	Lever	Gear/Actuator
/F Lining standard	2", 3", 4", 6", 8" DN 50, 80, 100, 150, 200	2", 3", 4", 6"-16" DN 50, 80, 100, 150-400	2 1/2", 5" DN 65, 125	2 1/2", 5" DN 65, 125	2", 3", 4", 6", 8" DN 50, 80, 100, 150, 200	2", 3", 4", 6"-16" DN 50, 80, 100, 150-400	2 1/2", 5" DN 65, 125	2 1/2", 5", 18"-30" DN 65, 125, 450-750	2", 3", 4", 6", 8" DN 50, 80, 100, 150, 200	2", 3", 4", 6"-12" DN 50, 80, 100, 150-300
/F-L Lining antistatic	100, 150, 200	2", 3", 4", 6"-12" DN 50, 80, 100, 150-300		2 1/2", 5", 14"-16" DN 65, 125 350-400		2", 3", 4", 6"-12" DN 50, 80, 100, 150-300		2 1/2", 5", 14"-24" DN 65, 125, 350-600		
Body design	 Wafer-style body				 Lug-style body				 Double-flange body	

Hand lever dimensions (inch) and approx. weights (lbs)

inch	2"	2 1/2"	3"	4"	5"	6"	8"	10"	12"	14"	16"	18"	20"	24"	28"	30"	
DN	50	65	80	100	125	150	200	250	300	350	400	450	500	600	700	-	
a	2.6	1.4	2.6	2.4	1.8	2.8	2.8	Worm gear, see page 7									
l	12	9	12	12	11	20	20										
h	1.6	1.8	1.6	1.6	2.2	1.9	1.9										
Weight	1.5	1.5	1.5	1.5	2.4	8.2	8.2										

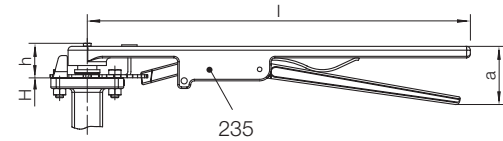

Hand lever 2"-8" (DN 50-200) for valves with PFA-lined disc (except 2 1/2"+5" (DN 65+125), see page 8)

Pipeline connections and approx. weights (lbs)

inch	2"	2 1/2"	3"	4"	5"	6"	8"	10"	12"	14"	16"	18"	20"	24"	28"	30" ³⁾
DN	50	65	80	100	125	150	200	250	300	350	400	450	500	600	700	-
K (ASME)	121	140	153	191	216	242	299	362	432	476	540	578	635	749	864	914
nxd (ASME) ¹⁾	4x19	4x19	4x19	8x19	8x22	8x22	8x22	12x26	12x26	13x29.5	16x29.5	16x32	20x32	20x35	28x35	28x35
n ²⁾	4x5/8"	4x5/8"	4x5/8"	8x5/8"	8x3/4"	8x3/4"	8x3/4"	12x7/8"	12x7/8"	12x1"	16x1"	16x1/8"	20x1/8"	20x1/4"	28x1/4"	28x1/4"
K (ISO)	125	145	160	180	210	240	295	350	400	460	515	565	620	725	840	-
nxd (ISO) ¹⁾	4x19	8x18	8x19	8x19	8x18	8x23	8x23	12x23	12x23	16x23	16x28	20x26	20x26	20x30	24x30	-
n ²⁾	4xM16	8xM16	8xM16	8xM16	8xM16	8xM20	8xM20	12xM20	12xM20	16xM20	16xM24	20xM24	20xM24	20xM27	24xM27	-
NKS, NKS-C (lbs)	8	9	10	13	17	33	24	55	73	104	152	335	408	560	617	661
NKL, NKL-C (lbs)	10	15	17	21	32	51	35	77	119	150	214	335	408	560	617	661
NK (lbs)	9	-	11	17	-	27	43	64	105	-	-	-	-	-	-	-

Flange connecting dimensions to ASME (ANSI) 16.5 Cl. 150 and ISO 7005-2 PN 10, weight (lbs) with bare shaft (without lever, bracket etc.)

¹⁾ Flange through holes on request ²⁾ Tapped holes metric or UNC ³⁾ DN 750 (30") only to ASME/ANSI B16.5 Cl. 150

Connection dimensions (inch)

inch	2"	2 1/2"	3"	4"	5"	6"	8"	10"	12"	14"	16"	18"	20"	24"	28"	30"
DN	50	65	80	100	125	150	200	250	300	350	400	450	500	600	700	-
L	1.7	1.8	1.8	2.1	2.2	2.2	2.4	2.7	3.1	3.1	4	4.5	5	6.1	6.5	7.5
H	5.3	5.8	6.3	6.9	8	8.4	9.1	10.7	11.7	13.2	14.2	15.8	17.1	20.1	22.9	23.9
B (NKS, NKS-C)	2.8	2.6	3.5	3.9	4.3	5	6.5	7.7	8.9	10.2	11.1	like NKL/NKL-C but through holes				
B (NKL, NKL-C)	2.8	2.6	3.5	3.9	4.6	5	6.5	7.7	8.9	10.2	11.1	12.2	13.4	15.7	22.9	23.9
B (NK)	2.6	-	3.7	4.2	-	5.3	6.5	7.7	9.1	-	-	-	-	-	-	-
E	1.1	1.9	2.6	3.4	4.7	5.6	7.6	9.6	11.5	13.5	15.3	16.4	18.8	22.1	26.2	28.2
T	0.2	0.4	0.7	1	1.5	1.9	2.8	3.6	4.4	5.4	5.9	6.5	7.2	8.5	10.4	11.4
C	3.5	4.2	5	5.9	6.5	8.4	10.4	12.4	14.4	16.9	18.9	20.3	22.4	26.5	31	33.5
F	0.1	0.02	0.1	0.1	0.02	0.1	0.1	0.2	0.2	0.2	0.2	0.02	0.02	0.02	0.04	0.04
G ¹⁾	0.4	-	0.4	0.5	-	0.6	0.6	0.6	0.8	-	-	-	-	-	-	-
A	1.2	0.8	1.2	1.2	1	1.4	1.4	1.7	1.7	2	2	2	2	2.5	2.5	2.2
Ø S	0.6	0.6	0.6	0.8	0.7	1	1	1.2	1.3	1.4	1.6	1.9	1.9	2.4	2.4	2.8
SW	0.4	0.4	0.4	0.5	0.6	0.7	0.7	0.9	0.9	1	1.2	-	-	-	-	-
SW square-end	-	-	-	-	-	-	-	-	-	-	-	1.4	1.4	1.8	1.8	2.2
M	0.6	0.7	0.6	0.6	1	0.8	0.8	1	1	1.4	1.4	2	2	2.5	2.5	2.2

¹⁾ Dimension G only applies to double-flange bodies

Connection dimensions (inch) for remotely actuated version

inch	2"	2 1/2"	3"	4"	5"	6"	8"	10"	12"	14"	16"	18"	20"	24"	28"	30"
DN	50	65	80	100	125	150	200	250	300	350	400	450	500	600	700	-
g	2.4	2.4	2.4	2.4	2.4	3.2	3.2	3.2	3.2	3.9	3.9	3.2	3.2	3.9	3.9	7.9
Conn. dim.*	F07	F07	F07	F07	F07	F10	F10	F12	F12	F14	F14	F14	F14	F16	F16	F25

* to ISO 5211

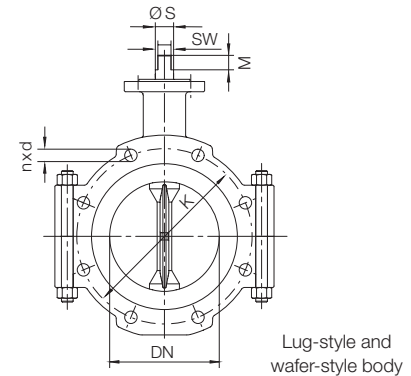

Lug-style and wafer-style body

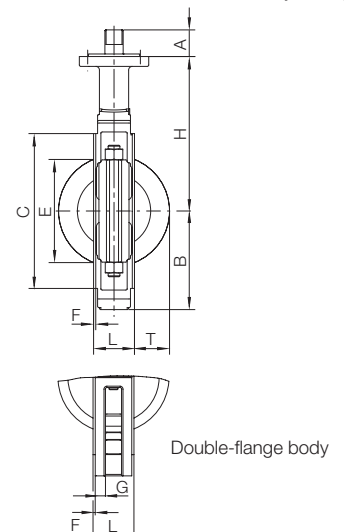

Double-flange body

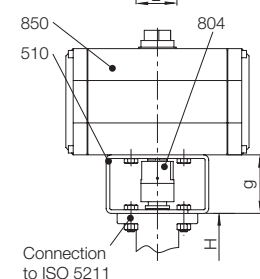

Connection to ISO 5211

Worm gear dimensions (inch) and approx. weights (lbs)

inch	2"	2 1/2"	3"	4"	5"	6"	8"	10"	12"	14"	16"	18"	20"	24"	28"	30"
DN	50	65	80	100	125	150	200	250	300	350	400	450	500	600	700	-
b	2.9	2.4	2.9	2.9	2.4	2.9	2.9	4.1	4.1	5	5	4.8	4.8	7.3	7.3	7.3
c	2	1.8	2	2	1.8	2.5	2.5	2.7	2.7	3.9	3.9	3.3	3.3	5.5	5.5	5.5
e	1.8	1.7	1.8	1.8	1.7	1.8	1.8	2.8	2.8	3.4	3.4	3.3	3.3	5.4	5.4	5.4
g*	2.4	2.4	2.4	2.4	2.4	3.2	3.2	3.2	3.2	3.9	3.9	3.2	3.2	3.9	3.9	7.9
k*	3.9	4.9	5.9	5.9	4.9	5.9	5.9	9.8	9.8	9.8	9.8	11.8	11.8	15.8	15.8	19.7
m	3.4	3.5	3.4	3.4	3.5	4.2	4.2	4.7	4.7	5.6	5.6	4.9	4.9	6.1	6.1	10
p	1.1	1.1	1.1	1.1	1.1	1.1	1.1	1.6	1.6	1.7	1.7	1.8	1.8	2.2	2.2	2.2
r	7.1	5	7.1	7.1	5	7.1	7.1	8.1	8.1	8.9	8.9	11.4	11.4	15.3	15.3	16.1
s	2.4	2.5	2.4	2.4	2.5	2.4	2.4	3.5	3.5	3.5	3.5	3.8	3.8	5	5	5
t	4	3.3	4	4	3.3	4.9	4.9	5.1	5.1	7.9	7.9	6.1	6.1	11.1	11.1	11.1
u*	4.8	4.9	4.8	4.8	4.9	5.6	5.6	6.6	6.6	7.5	7.5	7	7	9	9	12.9
Weight	9	9	9	9	9	11	11	22	22	33	33	31	31	71	71	71

* for valves with safety stuffing box

Torques (lbs-in)

inch	2"	2 1/2"	3"	4"	5"	6"	8"	10"	12"	14"	16"	18"	20"	24"	28"	30"
DN	50	65	80	100	125	150	200	250	300	350	400	450	500	600	700	-
Md	177	310	407	558	708	1133	1637	2540	3629	4868	5753	5311	5753	6638	13276	17702
Md _{adm}	885	540	1593	3186	1584	6417	6859	12701	15710	26553	30978	17259	21242	28322	28322	70806

Md_{adm} = max. admissible torque (Nm) with the disc/stem unit blocked

Flow rates (USgpm) and z-values

inch	2"	2 1/2"	3"	4"	5"	6"	8"	10"	12"	14"	16"	18"	20"	24"	28"	30"	
DN	50	65	80	100	125	150	200	250	300	350	400	450	500	600	700	-	
Angle of opening	20°	1.2	4.7	5.8	12.8	28.0	43.1	72.2	99	185.2	268	343.7	512.6	667.5	927.3	1532	1633
	30°	7	16.3	25.6	31.5	84.0	97.9	198.1	332	490.5	710.7	908.7	1455	1879	2629	4371	4689
	40°	15.1	31.5	54.8	60.6	148.0	191.1	412.4	596.5	972.8	1410	1806	2322	2980	4195	7019	7583
	50°	28.0	57.1	95.5	108.3	243.5	321.5	619.8	1028	1605	2330	2982	3531	4503	6382	10754	11707
	60°	47.8	93.2	146.8	180.6	386.8	502.1	1063	1690	2659	3845	4940	5326	6741	9623	16341	17934
	70°	78.1	137.5	229.5	287.8	555.7	817.8	1597	2,628	4232	6140	7281	7190	9028	12989	22242	24621
	80°	121.1	184.1	307.6	480	749.1	1323	2577	4301	6681	9693	12407	9170	11411	16564	28622	27442
90°	139.8	245.8	328.5	531.2	973.9	1461	2916	4757	7586	11009	14097	11450	14152	20683	35983	40477	

Conversion to Cv = K_v x 1.165 (USgpm) = K_v x 0.971 (Imp gpm)

z-values at 75 % flow															
0.32	0.46	0.63	0.29	0.40	0.26	0.23	0.19	0.16	0.14	0.12	0.49	0.49	0.48	0.29	0.30

Standard design worm gear

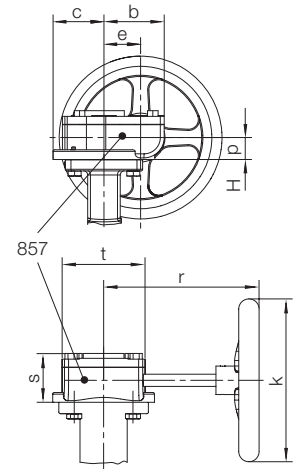

Construction worm gear for butterfly valve with safety stuffing box

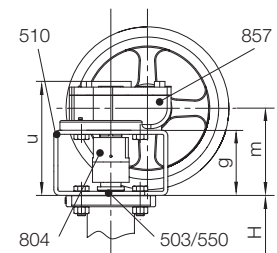

Pressure/temperature range*

NK, NKS, NKL with PFA-lined disc
Body lining PTFE

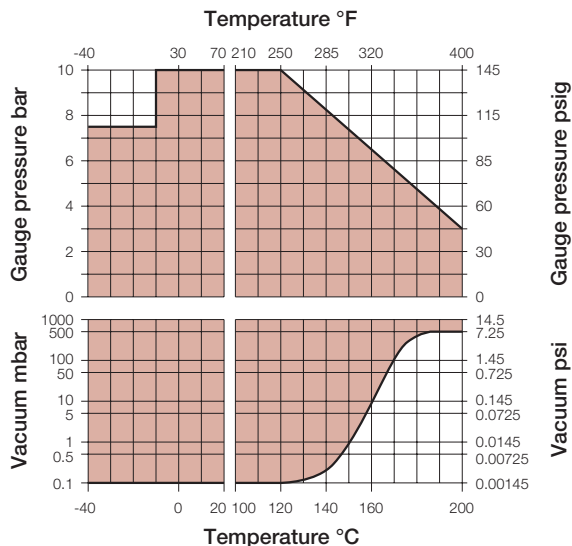

* A special material is used for the disc/stem core in case of operating temperatures below -4 °F (-20 °C).
For low temperature applications please observe local regulations!

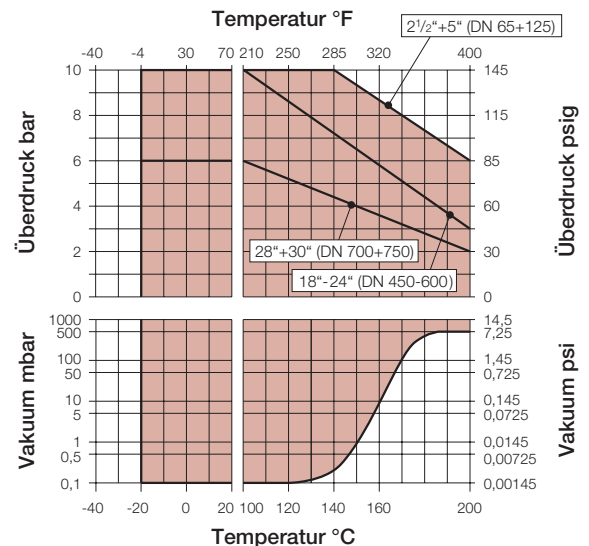

Pressure/temperature range

NKS-C, NKL-C with PFA-lined disc
Body lining TFM-PTFE



For low temperature applications please observe local regulations!

Connection dimensions, flow rates, torques TFM-PTFE butterfly valves with **stainless steel/Hastelloy® C/titanium disc**

Series	NKS-C, NKSP-C				NKL-C, NKLP-C			
	Lever		Gear/Actuator		Lever		Gear/Actuator	
/F Lining standard	2"-8" DN 50-200		2"-12" DN 50-300		2"-8" DN 50-200		2"-40" DN 50-1000	
/F-L Lining antistatic			2"-12" DN 50-300				2"-24" DN 50-600	
Body design	 Wafer-style body				 Lug-style body			

Hand lever 2"-8" (DN 50-200)
for valves with metal disc and 2 1/2"+5" (DN 65+125)
for valves with PFA-lined disc

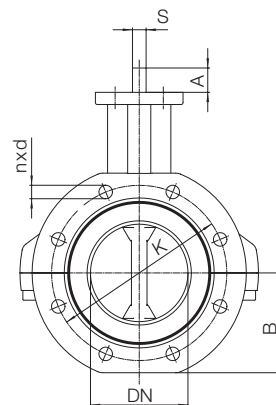
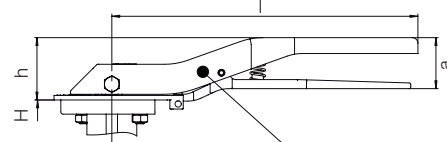

Hand lever dimensions (inch) and approx. weights (lbs)

inch	2"	2 1/2"	3"	4"	5"	6"	8"	10"	12"	14"	16"	18"	20"	24"	28"	30"	32"	36"	40"
DN	50	65	80	100	125	150	200	250	300	350	400	450	500	600	700	-	800	900	1000
a	1.4	1.4	1.4	1.8	1.8	1.8	1.8	Worm gear, see page 9											
l	9.1	9.1	9.1	10.6	10.6	12.8	13.7												
h	1.8	1.8	1.8	2.2	2.2	2.2	2.2												
Weight	1.8	1.8	1.8	2.4	2.4	3.1	4.2												

Pipeline connections and approx. weights (lbs)

inch	2"	2 1/2"	3"	4"	5"	6"	8"	10"	12"	14"	16"	18"	20"	24"	28"	30" ³⁾	32"	36"	40"
DN	50	65	80	100	125	150	200	250	300	350	400	450	500	600	700	-	800	900	1000
K (ASME)	121	140	152	191	216	241	298	362	432	476	540	578	635	749	864	914	978	1086	1200
nxd (ASME) ¹⁾	4x19	4x19	4x19	8x19	8x22	8x22	8x22	12x26	12x26	12x29	16x29	16x32	20x32	20x35	28x35	28x35	28x42	32x42	36x42
n ²⁾	4x5/8"	4x5/8"	4x5/8"	8x5/8"	8x3/4"	8x3/4"	8x3/4"	12x7/8"	12x7/8"	12x1"	16x1"	16x1/8"	20x1/8"	20x1/4"	28x1/4"	28x1/4"	28x1/2"	32x1/2"	36x1/2"
K (ISO)	125	145	160	180	210	240	295	350	400	460	515	565	620	725	840	-	950	1050	1160
nxd (ISO) ¹⁾	4x18	8x18	8x18	8x18	8x18	8x22	8x22	12x22	12x22	16x22	16x26	20x26	20x26	20x30	24x30	-	24x33	28x33	28x36
n ²⁾	4xM16	8xM16	8xM16	8xM16	8xM16	8xM20	8xM20	12xM20	12xM20	16xM20	16xM24	20xM24	20xM24	20xM27	24xM27	-	24xM30	28xM30	28xM33
NKS-C (lbs)	6.6	8.8	11	13.9	17	22	36.4	54	81.6	192	235.9	335.1	407.9	560	617.3	661.4	903.9	1014	1058
NKL-C (lbs)	11.0	15.4	17.9	23.8	32	34.8	54.2	73.4	125.7	192	235.9	335.1	407.9	560	617.3	661.4	903.9	1014	1058

Flange connecting dimensions to ASME (ANSI) 16.5 Cl. 150 and ISO 7005-2 PN 10, weight (lbs) with bare shaft (without lever, bracket etc.)

¹⁾ Flange through holes on request ²⁾ Tapped holes metric or UNC ³⁾ 30" (DN 750) only to ASME/ANSI B16.5 Cl. 150

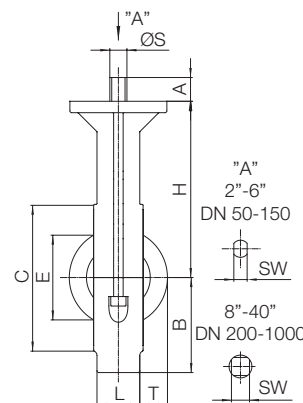

Connection dimensions (inch)

inch	2"	2 1/2"	3"	4"	5"	6"	8"	10"	12"	14"	16"	18"	20"	24"	28"	30"	32"	36"	40"
DN	50	65	80	100	125	150	200	250	300	350	400	450	500	600	700	-	800	900	1000
L*	1.7	1.8	1.8	2.1	2.2	2.2	2.4	2.7	3.1	3.1	4	4.5	5	6.1	6.5	7.5	7.5	8	8.5
H	5.1	5.8	6.5	7.3	8.0	8.5	9.7	10.6	12.1	13.0	14.4	15.8	17.1	20.1	22.9	23.9	24.8	26.9	30.4
B (für NKS-C)	2.2	2.6	3.3	3.9	4.3	4.9	6.2	7.5	8.9	like NKL-C, but through holes									
B (für NKL-C)	2.3	2.6	3.5	4.0	4.6	5	6.3	7.6	8.9	10.1	11.5	12.2	13.4	15.7	22.9	23.9	24.8	26.9	30.4
E	1.2	1.9	2.5	3.5	4.7	5.4	7.4	9.4	11.4	12.9	14.8	16.4	18.8	22.1	26.2	28.2	30.2	33.9	38.2
T	0.2	0.4	0.7	1.1	1.5	1.9	2.8	3.6	4.4	4.9	5.8	6.5	7.2	8.5	10.4	11.4	12.4	14.2	16.3
C	3.4	4.2	4.8	5.6	6.5	7.6	9.9	11.8	13.7	16.3	18.1	20.3	22.4	26.5	31	33.5	35.2	40	43.4
F	0.02	0.02	0.02	0.02	0.02	0.02	0.02	0.02	0.02	0.02	0.02	0.02	0.02	0.02	0.04	0.04	0.04	0.04	0.04
A	0.8	0.8	0.8	1	1	1.2	1	1.2	1.2	1.5	1.5	2	2	2.5	2.5	2.2	2.2	2.2	3
Ø S	0.6	0.6	0.6	0.7	0.7	0.9	1	1.1	1.1	1.4	1.4	1.9	1.9	2.4	2.4	2.8	2.8	2.8	3.9
SW	0.4	0.4	0.4	0.6	0.6	0.7	-	-	-	-	-	-	-	-	-	-	-	-	-
SW square-end	-	-	-	-	-	-	0.8	0.9	0.9	1.1	1.1	1.4	1.4	1.8	1.8	2.2	2.2	2.2	3

* DN 300, 700-1000 not to ISO 5752 series 20, DIN EN 558-1 series 20

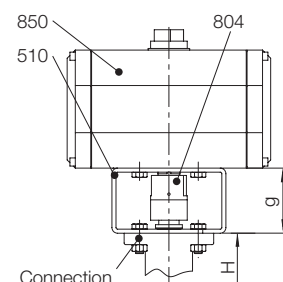

Connection dimensions (inch) for remotely actuated version

inch	2"	2 1/2"	3"	4"	5"	6"	8"	10"	12"	14"	16"	18"	20"	24"	28"	30"	32"	36"	40"
DN	50	65	80	100	125	150	200	250	300	350	400	450	500	600	700	-	800	900	1000
g	2.4	2.4	2.4	2.4	2.4	2.4	3.2	3.2	3.2	3.2	3.2	3.2	3.2	3.9	3.9	7.9	7.9	7.9	7.9
Conn. dim.*	F07	F07	F07	F07	F07	F07	F10	F10	F10	F12	F12	F14	F14	F16	F16	F16	F25	F25	F30

* to ISO 5211

Worm gear dimensions (inch) and approx. weights (lbs)

inch	2"	2 1/2"	3"	4"	5"	6"	8"	10"	12"	14"	16"	18"	20"	24"	28"	30"	32"	36"	40"
DN	50	65	80	100	125	150	200	250	300	350	400	450	500	600	700	-	800	900	1000
b	2.7	2.7	2.7	2.7	2.7	3.2	3.2	3.2	4.5	4.5	4.5	4.8	4.8	7.3	7.3	7.3	7.3	7.3	7.3
c	1.8	1.8	1.8	1.8	1.8	2.2	2.2	2.2	2.9	2.9	2.9	3.3	3.3	5.5	5.5	5.5	5.5	5.5	5.5
e	1.7	1.7	1.7	1.7	1.7	2.1	2.1	2.1	2.7	2.7	2.7	3.3	3.3	5.4	5.4	5.4	5.4	5.4	5.4
k	4.9	4.9	4.9	4.9	4.9	7.9	7.9	7.9	9.8	9.8	9.8	11.8	11.8	15.7	15.7	19.7	23.6	23.6	15.7
p	1.1	1.1	1.1	1.1	1.1	1.3	1.3	1.3	1.7	1.7	1.7	1.8	1.8	2.2	2.2	2.2	2.2	2.2	2.2
r	5	5	5	5	5	8.5	8.5	8.5	10.5	10.5	10.5	11.4	11.4	15.3	15.3	16.1	16.7	16.7	17.2
s	2.5	2.5	2.5	2.5	2.5	3	3	3	3.6	3.6	3.6	3.8	3.8	5	5	5	5	5	5
t	3.3	3.3	3.3	3.3	3.3	4.4	4.4	4.4	5.3	5.3	5.3	6.1	6.1	11.1	11.1	11.1	11.1	11.1	11.1
Weight	4.4	4.9			9.5			18.7			25.4			76.1			91.5		

Standard design worm gear

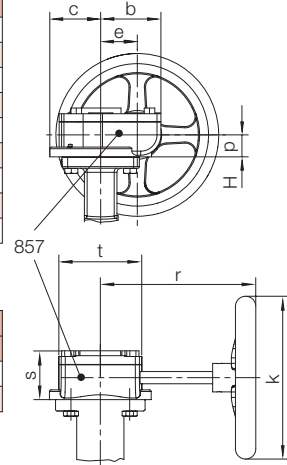

Torques (lbs-in)

inch	2"	2 1/2"	3"	4"	5"	6"	8"	10"	12"	14"	16"	18"	20"	24"	28"	30"	32"	36"	40"
DN	50	65	80	100	125	150	200	250	300	350	400	450	500	600	700	-	800	900	1000
Md	266	310	398	531	708	974	1682	2655	3540	3983	4425	5311	5753	6638	13276	17702	20357	23897	30093
Md _{adm}	540	540	540	1584	1584	2735	2735	5346	5346	10621	14161	17259	21242	28322	28322	70806	70806	70806	70806

Md_{adm} = max. admissible torque (Nm) with the disc/stem unit blocked

Flow rates (USgpm) and z-values

inch	2"	2 1/2"	3"	4"	5"	6"	8"	10"	12"	14"	16"	18"	20"	24"	28"	30"	32"	36"	40"	
DN	50	65	80	100	125	150	200	250	300	350	400	450	500	600	700	-	800	900	1000	
Angle of opening	20°	2.2	5.1	8.6	19.7	27.6	45	99	128.2	203.9	283.1	362.3	512.6	667.5	927.3	1532	1633	1767	2083	2264
	30°	7.7	16.3	27	61	83.9	134	291.2	372.8	590	813.1	1033	1455	1879	2629	4371	4689	5107	6063	6589
	40°	15.8	31.9	51.1	111.8	148	228.3	483.5	614	960	1315	1659	2322	2980	4195	7019	7583	8326	9968	10833
	50°	29.3	57.6	88.5	188.7	243.5	370.5	766.6	963.5	1495	2029	2542	3532	4503	6382	10754	11707	12959	15654	17012
	60°	47.5	93.2	142.1	300.6	386.8	586	1207	1503	2309	3109	3862	5326	6741	9623	16341	17934	20024	24408	26527
	70°	71.1	137.5	207.3	435.7	555.7	834.1	1704	2101	3199	4269	5256	7190	9028	12989	22242	24621	27740	34131	37095
	80°	96.7	184.1	283.1	589.5	749.1	1120	2279	2781	4194	5544	6765	9170	11411	16564	28622	31977	36368	45183	49107
90°	128.1	245.8	370.5	768.9	973.9	1449	2939	3570	5345	7018	8505	11450	14152	20683	35983	40477	46354	57991	63027	

Conversion to Cv = k_v x 1.165 (USgpm) = k_v x 0.971 (Imp gpm)

z-values at 75 % flow																			
0.60	0.46	0.47	0.27	0.40	0.38	0.29	0.48	0.45	0.48	0.56	0.49	0.49	0.48	0.29	0.30	0.30	0.31	0.40	

Pressure/temperature range

NKS-C, NKL-C with disc made of stainless steel, Hastelloy® C, titanium

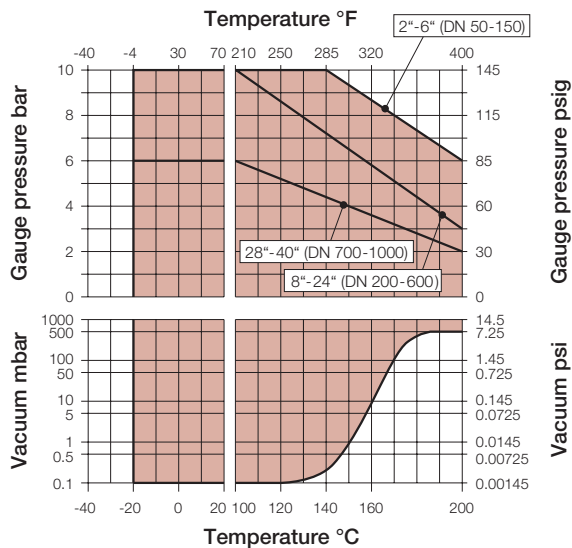

For low temperature applications please observe local regulations!

Overview of Richter butterfly valves with wafer-style, lug-style, double-flange-body

Body/Shell: Ductile cast iron¹⁾

Wafer-style body 2"-16" (DN 50-400)

Design	Material Body lining/disc	Manually actuated		Pneumatically actuated		Size (inch, mm)											
		Lining standard	Lining antistatic	Lining standard	Lining antistatic	2"	2 1/2"	3"	4"	5"	6"	8"	10"	12"	14"	16"	
						50	65	80	100	125	150	200	250	300	350	400	
	PTFE/PFA	NKS/F	NKS/F-L ²⁾	NKSP/F	NKSP/F-L ²⁾	•	•	•	•	•	•	•	•	•	•	•	
	TFM-PTFE/PFA	NKS/F	n.a.	NKSP/F	n.a.	•	•	•	•	•	•	•	•	•	•	•	
	TFM-PTFE/PFA	NKS-C/F	NKS-C/F-L	NKSP-C/F	NKSP-C/F-L	•	•	•	•	•	•	•	•	•	•	•	
	TFM-PTFE/stainl. steel	NKS-C/F-S	NKS-C/F-L-S	NKSP-C/F-S	NKSP-C/F-L-S	•	•	•	•	•	•	•	•	•	•	•	
	TFM-PTFE/Hastelloy® C22	NKS-C/F-H	NKS-C/F-L-H	NKSP-C/F-H	NKSP-C/F-L-H	•	•	•	•	•	•	•	•	•	•	•	
	TFM-PTFE/titanium gr. 2	NKS-C/F-T	NKS-C/F-L-T	NKSP-C/F-T	NKSP-C/F-L-T	•	•	•	•	•	•	•	•	•	•	•	
PE-UHMW/stainl. steel	NKS-C/E-S	n.a.	NKSP-C/E-S	n.a.	•	•	•	•	•	•	•	•	•	•	•		

Lug-style body 2"-16" (DN 50-400)

Design	Material Body lining/disc	Manually actuated		Pneumatically actuated		Size (inch, mm)											
		Lining standard	Lining antistatic	Lining standard	Lining antistatic	2"	2 1/2"	3"	4"	5"	6"	8"	10"	12"	14"	16"	
						50	65	80	100	125	150	200	250	300	350	400	
	PTFE/PFA	NKL/F	NKL/F-L ²⁾	NKLP/F	NKLP/F-L ²⁾	•	•	•	•	•	•	•	•	•	•	•	
	TFM-PTFE/PFA	NKL/F	n.a.	NKLP/F	n.a.	•	•	•	•	•	•	•	•	•	•	•	
	TFM-PTFE/PFA	NKL-C/F	NKL-C/F-L ²⁾	NKLP-C/F	NKLP-C/F-L ²⁾	•	•	•	•	•	•	•	•	•	•	•	
	TFM-PTFE/stainl. steel	NKL-C/F-S	NKL-C/F-L-S ²⁾	NKLP-C/F-S	NKLP-C/F-L-S ²⁾	•	•	•	•	•	•	•	•	•	•	•	
	TFM-PTFE/Hastelloy® C22	NKL-C/F-H	NKL-C/F-L-H ²⁾	NKLP-C/F-H	NKLP-C/F-L-H ²⁾	•	•	•	•	•	•	•	•	•	•	•	
	TFM-PTFE/titanium gr. 2	NKL-C/F-T	NKL-C/F-L-T ²⁾	NKLP-C/F-T	NKLP-C/F-L-T ²⁾	•	•	•	•	•	•	•	•	•	•	•	
PE-UHMW/stainl. steel	NKL-C/E-S	n.a.	NKLP-C/E-S	n.a.	•	•	•	•	•	•	•	•	•	•	•		

Lug-style body 18"-40" (DN 450-1000)

Design	Material Body lining/disc	Manually actuated		Pneumatically actuated		Size (inch, mm)							
		Lining standard	Lining antistatic	Lining standard	Lining antistatic	18"	20"	24"	28"	30"	32"	36"	40"
						450	500	600	700	750	800	900	1000
	TFM-PTFE/PFA	NKL-C/F	NKL-C/F-L ²⁾	NKLP-C/F	NKLP-C/F-L ²⁾	•	•	•	•	•	•	•	•
	TFM-PTFE/stainl. steel	NKL-C/F-S	NKL-C/F-L-S ²⁾	NKLP-C/F-S	NKLP-C/F-L-S ²⁾	•	•	•	•	•	•	•	•
	TFM-PTFE/Hastelloy® C22	NKL-C/F-H	NKL-C/F-L-H ²⁾	NKLP-C/F-H	NKLP-C/F-L-H ²⁾	•	•	•	•	•	•	•	•
	TFM-PTFE/titanium gr. 2	NKL-C/F-T	NKL-C/F-L-T ²⁾	NKLP-C/F-T	NKLP-C/F-L-T ²⁾	•	•	•	•	•	•	•	•
	PE-UHMW/stainl. steel	NKL-C/E-S	n.a.	NKLP-C/E-S	n.a.	•	•	•	•	•	•	•	•

¹⁾ optionally shell made of stainless steel and fibre-reinforced vinyl ester, available sizes on request ²⁾ DN ≥ 350 (14") antistatic: Availability on request

Double-flange body 2"-12" (DN 50-300)

Design	Material Body lining/disc	Manually actuated		Pneumatically actuated		Size (inch, mm)								
		Lining standard	Lining antistatic	Lining standard	Lining antistatic	2"	2 1/2"	3"	4"	5"	6"	8"	10"	12"
						50	65	80	100	125	150	200	250	300
	PTFE/PFA	NK/F	NK/F-L	NKP/F	NKP/F-L	•	•	•	•	•	•	•	•	•
	TFM-PTFE/PFA	NK/F	n.a.	NKP/F	n.a.	•	•	•	•	•	•	•	•	•

Presented by:

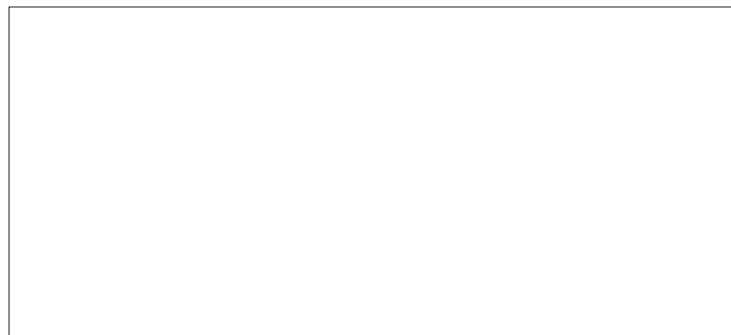

Richter Inc.

A Unit of IDEX Corporation

406 State Street, Cedar Falls, 50613 IA, USA

Tel. +1(319) 268-8038, Fax +1(803) 216-7702

Headquarter:

Richter Chemie-Technik GmbH

Otto-Schott-Str. 2, D-47906 Kempen, Germany

Tel. +49(0) 21 52/146-0, Fax +49(0) 21 52/146-190

www.richter-ct.com, richter-info@idexcorp.com